

VITO® 50

English



VITO® 50

VITO® 50 is suitable for fryers up to 44 lbs (20 l).

Functionality:

VITO® 50 cleans the oil and provides an easy and hygienic filtration in the kitchen. Like every VITO® oil filter system the VITO® 50 provides a microfiltration up to 5 µm. As an additional feature no chemicals are needed to clean the oil, which preserves the optimal taste of the fried dishes. The unique design makes sure the VITO® can handle temperatures up to 347°F (175°C) and provides highest safety at work, because of avoiding direct contact with the hot oil. After filtration the oil can be immediately used for frying again.

The VITO® 50 is a real economic miracle which saves oil, labour and stock ground.

To optimize the benefit of the VITO® 50 combine it with the VITO® oiltester.

All benefits at a glance:

Big savings potential:

- less oil consumption
- less personnel costs
- less storage costs
- fast amortization (4-12 months)

Quality:

- constant quality of fried dishes

Easy handling:

- automatic filtration
- fast filtration
- low cleaning effort

Your contact:

VITO AG
Eltastr. 6
78532 Tuttlingen, Germany

Phone: +49 7461 96289-0
Fax: +49 7461 96289-17

info@VITO.ag
www.VITO.ag



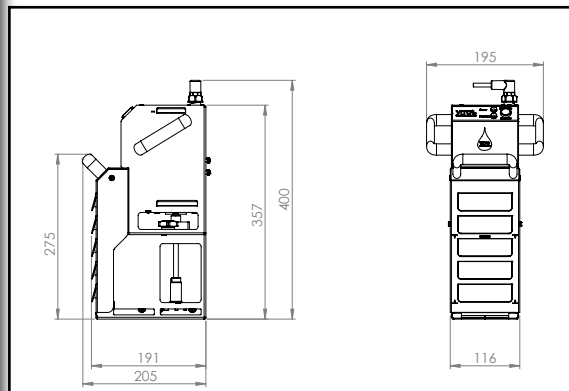
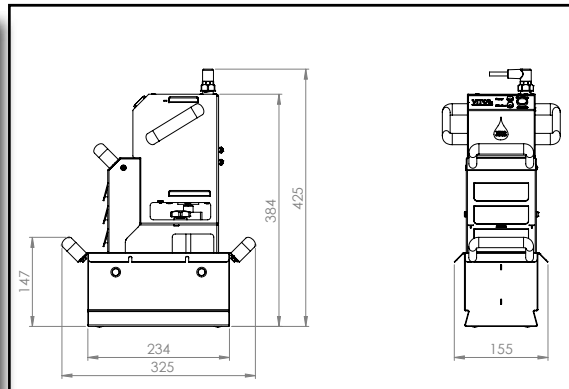
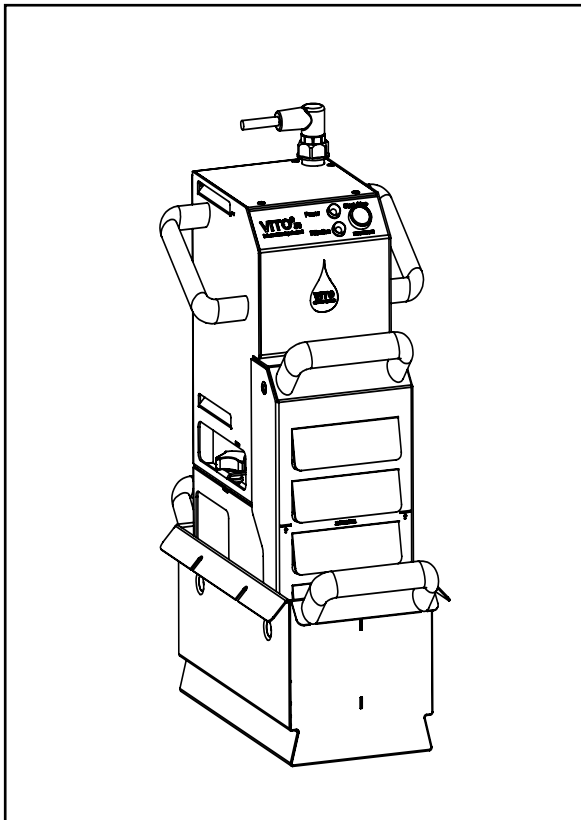

**Oil- and fat filtration system incl. particle filter
Made for filtration of frying oil and fat up to 130 lbs (60 l) per minute**

Format:

- The VITO® 50 can operate in deep fryers at service temperatures
- Cleans the oil of microparticles, carbonization and suspended sediments up to 5µm
- Filtration power up to 130 lbs (60 l) per minute
- Suction depth is up to 13.8 in (35 cm)
- Filtration cycle time 4,5 minutes (can be adjusted)
- Filterbox can be disassembled instantly
- Casing and filterbox are made of stainless steel 1.4301, filter made of cellulose
(All used components are food safe)

Technical data:

Lettered dimensions:

Width:	4.6 in	(116 mm)
Depth:	7.5 in	(191 mm)
Height:	15.8 in	(400 mm)
Weight:	17.0 lbs	(7,7 kg)

Shipping Dimensions:

Width:	15.8 in	(400 mm)
Depth:	19.7 in	(500 mm)
Height:	9.8 in	(250 mm)
Weight:	24.25 lbs	(11 kg)

Filtration efficiency: 5-20 µm

Max. power: 300 W

Power connection: 100-120 V (220-240 V), 50-60 Hz

