

FT 440 - Frying oil tester

Spec-Sheet



FT 440 frying oil tester - TPM & Temperature measurement

Functionality:

The FT 440 easily, quickly and reliably determines the quality of your oil. To do so, it measures the so-called „Total Polar Material“ (TPM) content in the oil and shows its value as an accurate percentage. The clear alarm via the coloured top alarm light makes it even easier to evaluate the quality of the oil. So you always know exactly when to change your oil. The FT 440 frying oil tester prevents the direct exposure of your hand to the hot oil.

To optimize the benefits of the FT 440 combine it with the VITO oil filter system.

All benefits at a glance:

- Measure the quality and temperature of your oil
- Change your oil at the right time
- Quick and reliable measuring results
- Supports HACCP quality standards
- Ergonomic and sturdy design
- High degree of protection (IP67)
- Clear alarms via on top alarm light using the traffic light principle



VITO AG
Tuttlingen, Germany
T: +49 7461 962890
F: +49 7461 9628912
info@vito.ag - www.vito.ag

FT 440

Frying oil tester

VITO[®]
oil filter system

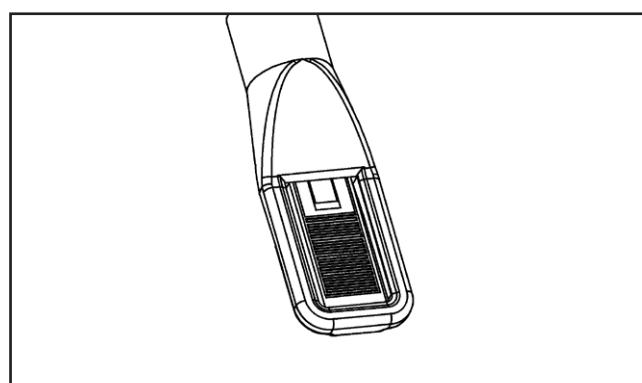
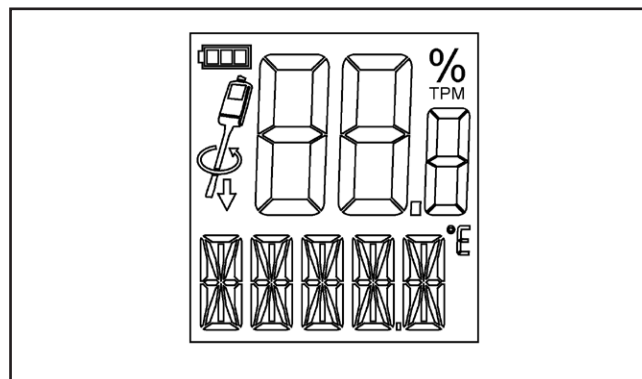
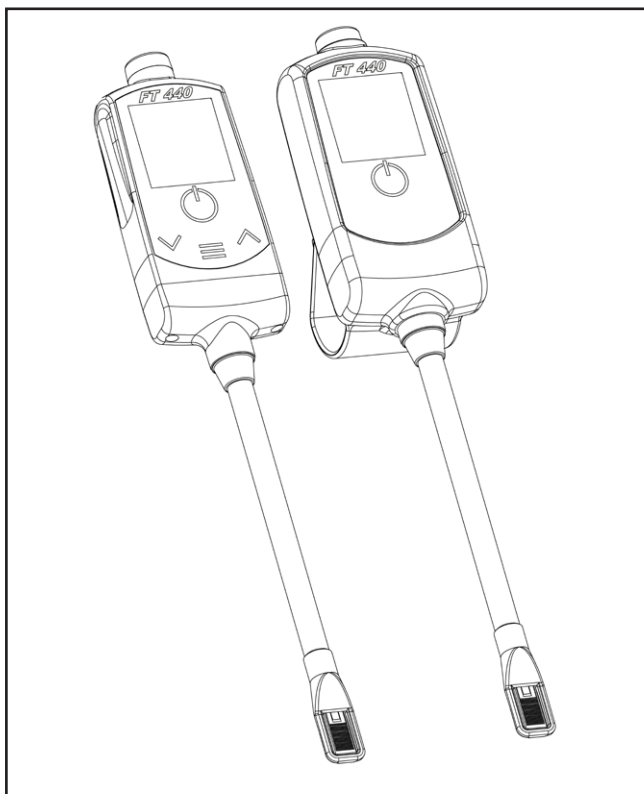

FT 440 frying oil tester - TPM & Temperature measurement

Technical data:

Measuring range	+50 °C...200 °C 0%...40% TPM +122 °F...392 °F
Accuracy	± 1 °C / °F ± 2 % TPM
Resolution	1 °C / °F 0,5 % TPM
Measured variables	temperature, TPM (total polar materials)
IP Rating	IP 67 (high degree of protection)
Battery	3 V Lithium (CR 2477)
Battery lifetime	up to 3 years
Dimensions	304 x 54 x 22 mm 11,9 x 2,1 x 0,9 inch
Weight	approx. 200 g approx. 0,44 lbs
Certificate	Factory calibration certificate



VITO AG
Tuttlingen, Germany

T: +49 7461 962890
F: +49 7461 9628912
info@vito.ag - www.vito.ag